

804LC Clamshell Lathe

Portable Machining Solutions



Mactech Europe offer portable pipe cutting machines for On-Site precision cutting and bevelling of most pipe sizes, schedules and materials.

The Clamshell Lathes cover a wide range of pipe sizes from 2" to 60" OD and are designed so that minimal radial and axial clearance are required for easy installation on in-line closed loop pipe.

Unlike other competitive cold cutters our lathes have more bearings making it the most versatile machine in the industry to cut and bevel pipe, re-machine flanges, machine shafts and more.

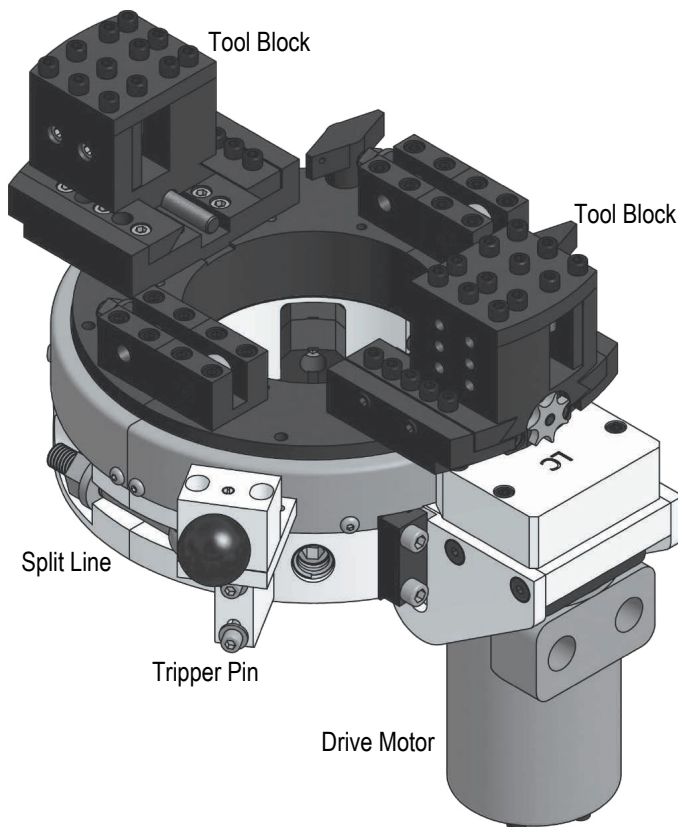

Mactech 804LC Clamshell



Features

- Sever or simultaneous Sever / Bevell 2" to 4" pipe.
- Cold Cutting in hazardous environments.
- Exceptionally rigid, split-frame for precise on-site machining.
- Lightweight, low clearance design for easy handling in tight workspaces.
- Air Caddy (air filter & oiler) included with air drive systems
- Customer setups and drives available for your application.

Mactech Europe Limited

Tel: + 44 (0) 1260 253846
Web: www.mactecheuropa.co.uk
Email: info@mactecheuropa.co.uk

UK Head Office: Unit 7 Scragg House | Langley | Macclesfield | Cheshire | SK11 0DG
Aberdeen Office: Mactech House | Howe Moss Drive | Dyce | Aberdeen | AB21 0GL



Rental Units
in the UK &
Internationally



Mactech Europe 804LC Clamshell Lathe



Mactech
(EUROPE) LIMITED

Mactech Europe

804LC Clamshell Lathe



Application Range	2" to 4" Nominal pipe	
Feed	Feed Mechanism	7 Point Star Wheel & tripper
	Feed Rate	.0035" (0.09 mm) per revolution
Drives	Air Drive Requirement 100cfm @ 100 psi (2.8m³/min @ 6.9 bar)	
	Hydraulic Drive HPU Requirement 10-15 gpm @1000 psi (38-57lpm@69 bar) continuous pressure	
Weights	Operating Weights include tool blocks, slides and drive motor 804LC Air Drive 63lbs (29kg) 804LC Hydraulic Drive 67lbs (30kg) Shipping Weights includes equipment and shipping crate 804LC Air Drive 152lbs (69kg) 804LC Hydraulic Drive 143lbs (65kg)	
Options	Full line of tool bits Right angle & reversible drives Single point machining attachment Axial Feed Machining attachment Counterbore / Facing attachment Hydraulic Power Unit	

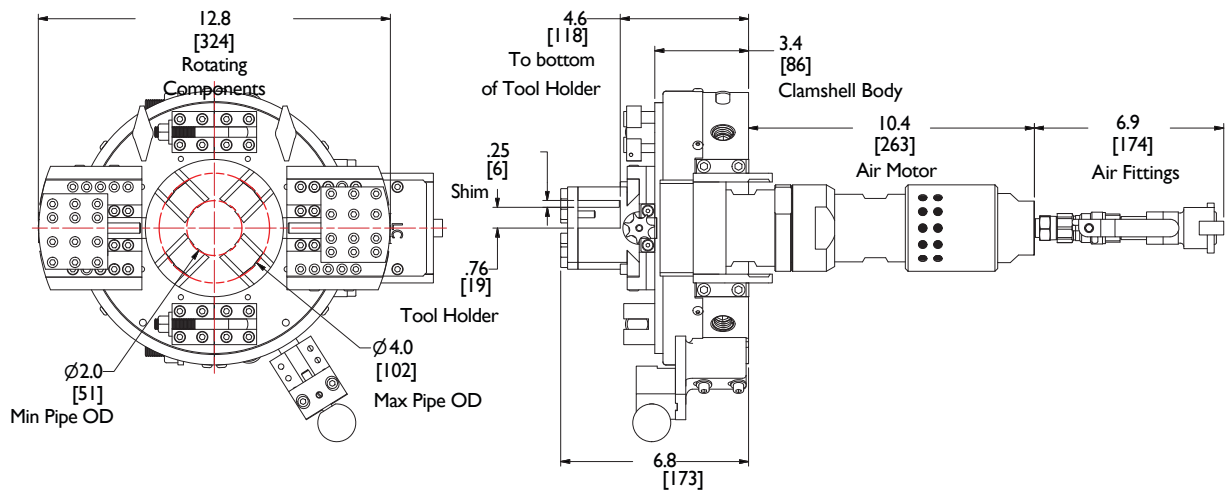

804LC with Air Drive

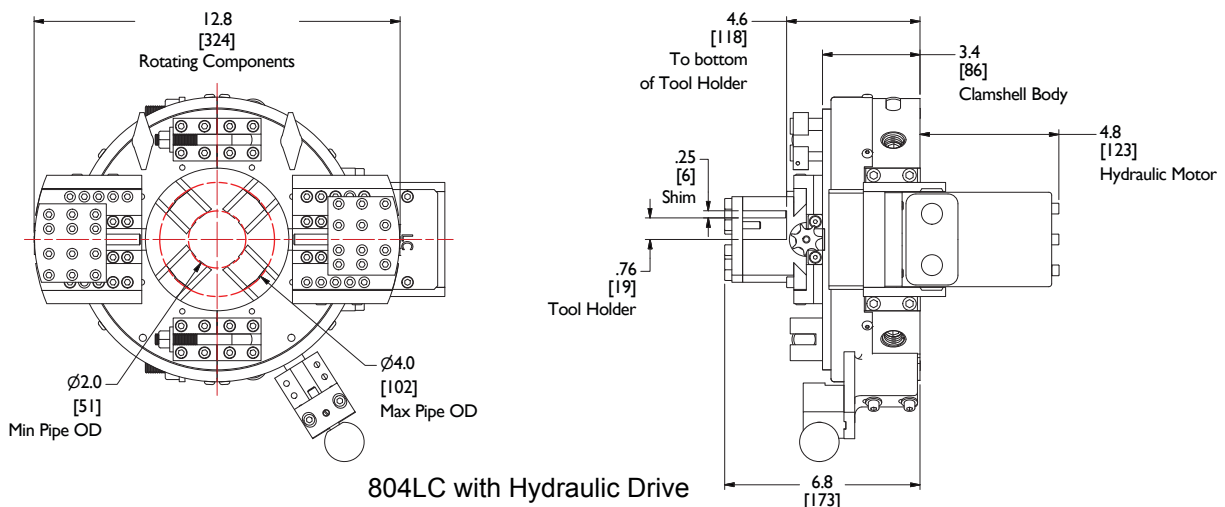

804LC with Hydraulic Drive

Mactech Europe Limited

Tel: + 44 (0) 1260 253846
Web: www.mactech europe.co.uk
Email: info@mactech europe.co.uk

UK Head Office: Unit 7 Scragg House | Langley | Macclesfield | Cheshire | SK11 0DG
Aberdeen Office: Mactech House | Howe Moss Drive | Dyce | Aberdeen | AB21 0GL

Rental Units
in the UK &
Internationally

Mactech Europe 806LC Clamshell Lathe

Mactech Europe

806LC Clamshell Lathe

Portable Machining Solutions



Mactech Europe offer portable pipe cutting machines for On-Site precision cutting and bevelling of most pipe sizes, schedules and materials.

The Clamshell Lathes cover a wide range of pipe sizes from 2" to 60" OD and are designed so that minimal radial and axial clearance are required for easy installation on in-line closed loop pipe.

Unlike other competitive cold cutters our lathes have more bearings making it the most versatile machine in the industry to cut and bevel pipe, re-machine flanges, machine shafts and more.

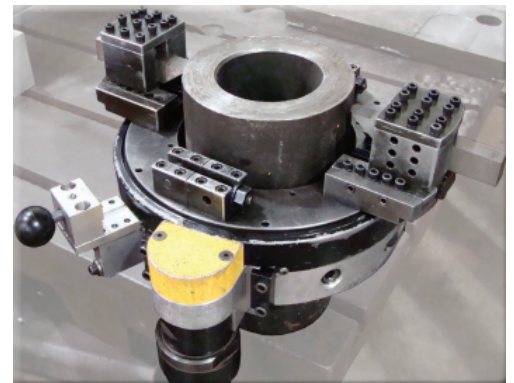
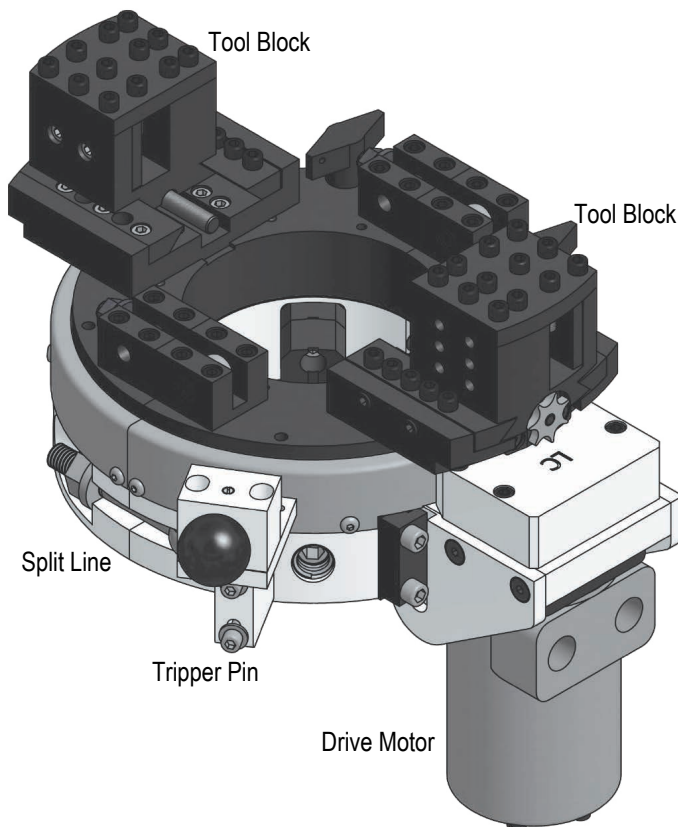

Mactech 806LC Clamshell



Features

- Sever or simultaneous Sever / Bevell 2" to 6" pipe.
- Cold Cutting in hazardous environments.
- Exceptionally rigid, split-frame for precise on-site machining.
- Tool Holder accepts standard 3/4" or 1" tool bits.
- Lightweight, low clearance design for easy handling in tight workspaces.
- Air Caddy (air filter & oiler) included with air drive systems
- Customer setups and drives available for your application.

Mactech Europe Limited

Tel: + 44 (0) 1260 253846
Web: www.mactech europe.co.uk
Email: info@mactech europe.co.uk

UK Head Office: Unit 7 Scragg House | Langley | Macclesfield | Cheshire | SK11 0DG
Aberdeen Office: Mactech House | Howe Moss Drive | Dyce | Aberdeen | AB21 0GL



Mactech
(EUROPE) LIMITED

Rental Units
in the UK &
Internationally



Mactech Europe 806LC Clamshell Lathe



Mactech
(EUROPE) LIMITED

Mactech Europe

806LC Clamshell Lathe



Application Range	2" to 6" Nominal Pipe	
Feed	Feed Mechanism	7 Point Star Wheel & tripper
	Feed Rate	.0035" (0.09 mm) per revolution
Drives	Air Drive Requirement 100cfm @ 100 psi (2.8m³/min @ 6.9 bar) Hydraulic Drive HPU Requirement 10-15 gpm @1000 psi (38-57lpm@69 bar) continuous pressure - includes hose whips and quick connects	
Weights	Operating Weights include tool blocks, slides and drive motor 806LC Air Drive 71lbs (32kg) 806LC Hydraulic Drive 75lbs (34kg) Approximate Shipping Weights includes equipment and shipping crate 806LC Air Drive 160lbs (73kg) 806LC Hydraulic Drive 151lbs (68kg)	
Options	Full line of tool bits Right angle & reversible drives Single point machining attachment Axial Feed Machining attachment Counterbore / Facing attachment Hydraulic Power Unit	

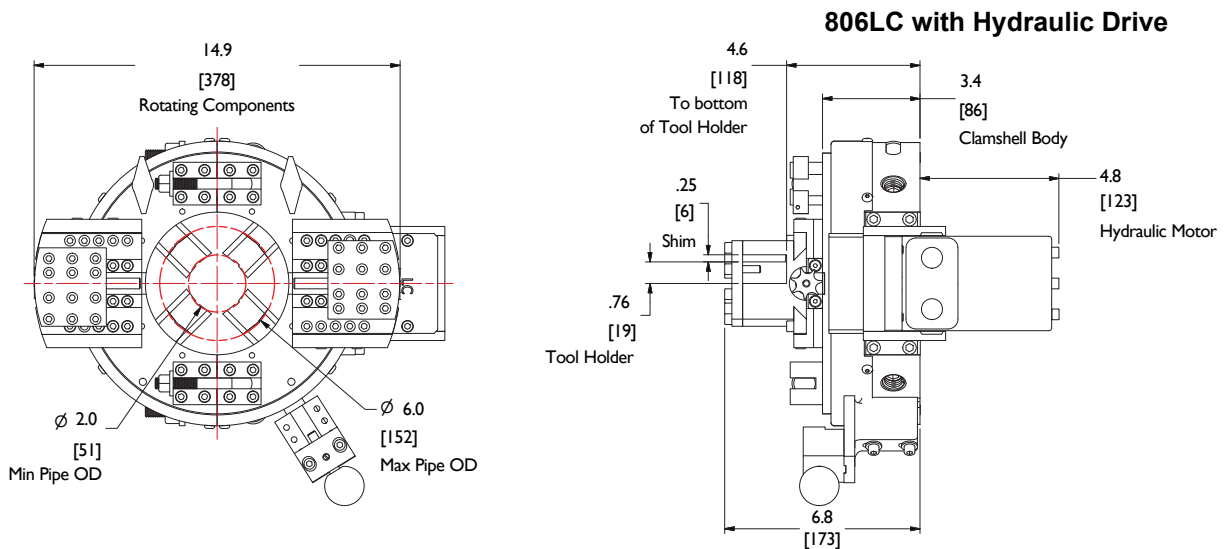
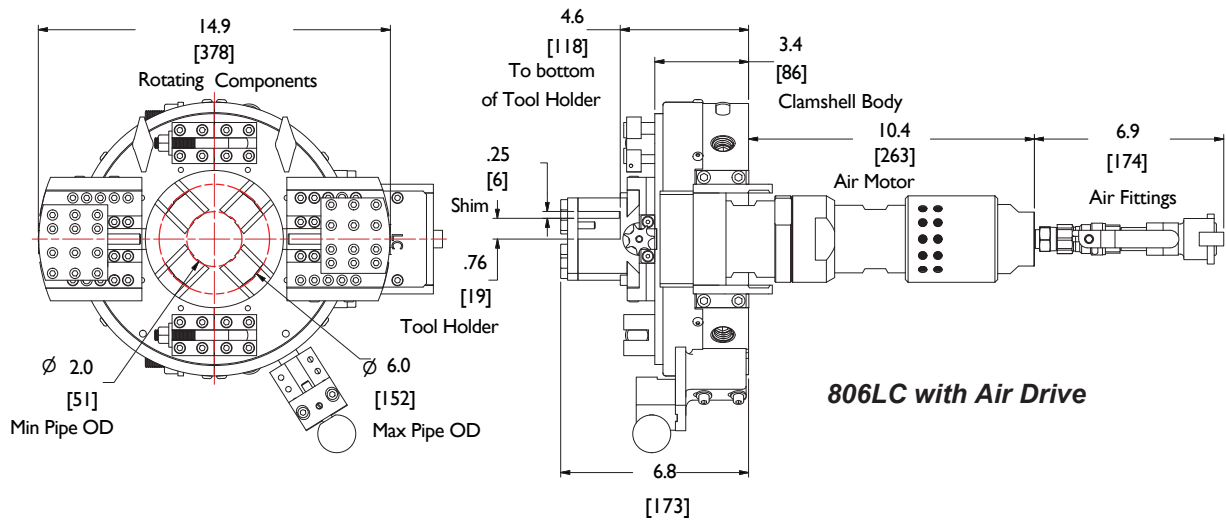

Mactech Europe Limited

Tel: + 44 (0) 1260 253846
Web: www.mactech europe.co.uk
Email: info@mactech europe.co.uk

UK Head Office: Unit 7 Scragg House | Langley | Macclesfield | Cheshire | SK11 0DG
Aberdeen Office: Mactech House | Howe Moss Drive | Dyce | Aberdeen | AB21 0GL

Rental Units
in the UK &
Internationally

Mactech Europe 808LC Clamshell Lathe

Mactech Europe

808LC Clamshell Lathe

Portable Machining Solutions



Mactech Europe offer portable pipe cutting machines for On-Site precision cutting and bevelling of most pipe sizes, schedules and materials.

The Clamshell Lathes cover a wide range of pipe sizes from 2" to 60" OD and are designed so that minimal radial and axial clearance are required for easy installation on in-line closed loop pipe.

Unlike other competitive cold cutters our lathes have more bearings making it the most versatile machine in the industry to cut and bevel pipe, re-machine flanges, machine shafts and more.

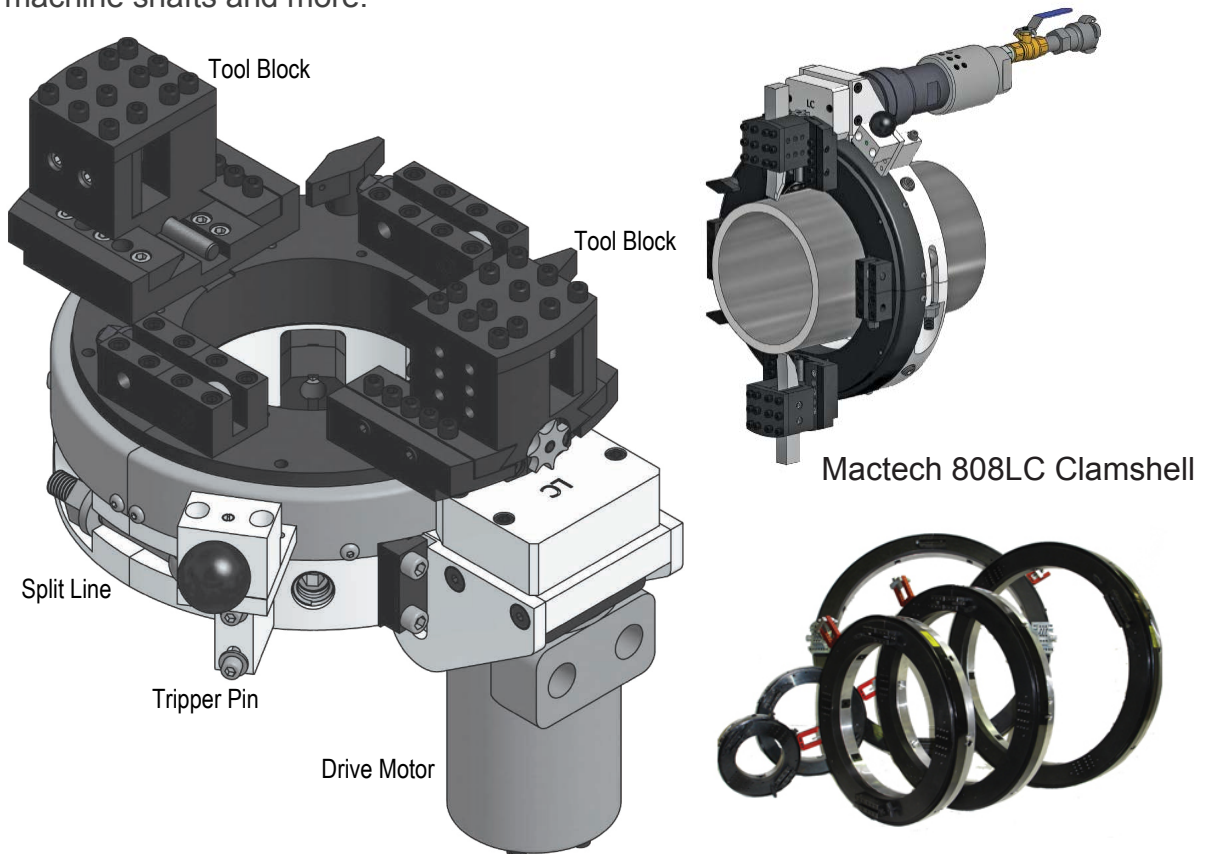

Features

- Sever or simultaneous Sever / Bevell 2" to 8" pipe.
- Cold Cutting in hazardous environments.
- Exceptionally rigid, split-frame for precise on-site machining.
- Tool Holder accepts standard 3/4" or 1" tool bits.
- Lightweight, low clearance design for easy handling in tight workspaces.
- Air Caddy (air filter & oiler) included with air drive systems
- Customer setups and drives available for your application.

Mactech Europe Limited

Tel: + 44 (0) 1260 253846
Web: www.mactech europe.co.uk
Email: info@mactech europe.co.uk

UK Head Office: Unit 7 Scragg House | Langley | Macclesfield | Cheshire | SK11 0DG
Aberdeen Office: Mactech House | Howe Moss Drive | Dyce | Aberdeen | AB21 0GL



Mactech
(EUROPE) LIMITED

Rental Units
in the UK &
Internationally



Mactech Europe 808LC Clamshell Lathe



Mactech
(EUROPE) LIMITED

Mactech Europe

808LC Clamshell Lathe



Application Range	2" to 8" Nominal pipe	
Feed	Feed Mechanism	7 Point Star Wheel & Tripper
	Feed Rate	.0035" (0.09 mm) per revolution
Drives	Air Drive Requirement 100cfm @ 100 psi (2.8m³/min @ 6.9 bar) Hydraulic Drive HPU Requirement 10-15 gpm @1000 psi (38-57lpm@69 bar) continuous pressure - includes hose whips and quick connects	
Weights	Operating Weights include tool blocks, slides and drive motor 808LC Air Drive 77lbs (35kg) 808LC Hydraulic Drive 81lbs (37kg) Approximate Shipping Weights includes equipment and shipping crate 808LC Air Drive 166lbs (75kg) 808LC Hydraulic Drive 157lbs (71kg)	
Options	Full line of tool bits Right angle & reversible drives Single point machining attachment Axial Feed Machining attachment Counterbore / Facing attachment Hydraulic Power Unit	

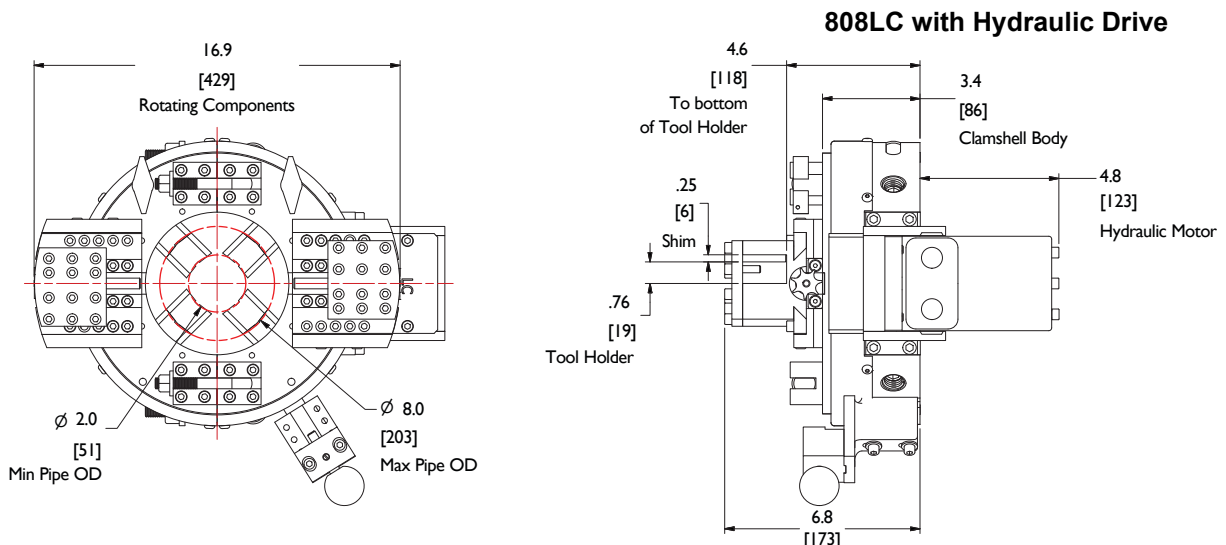
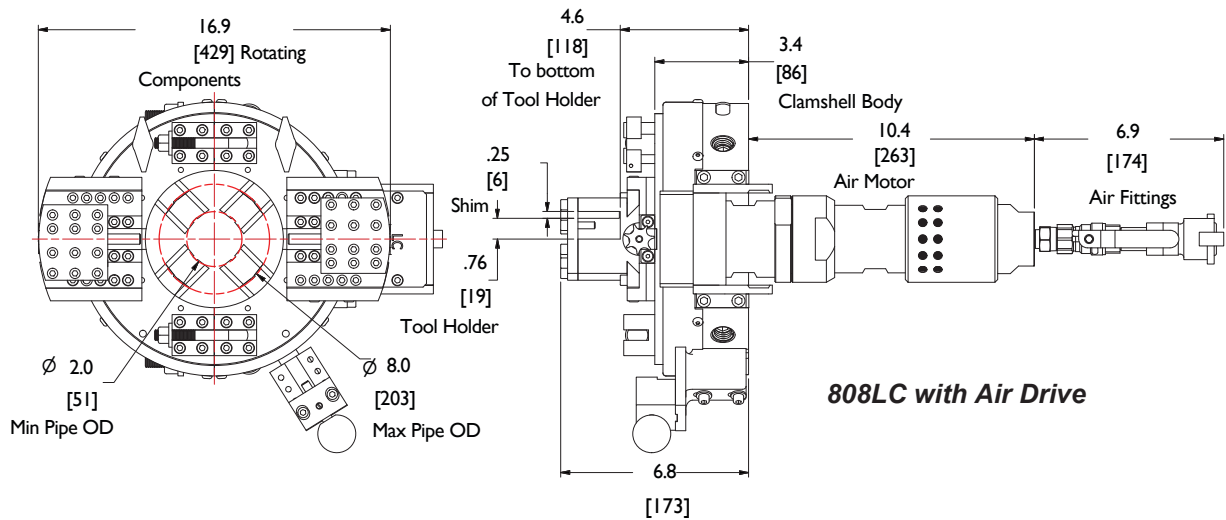

Mactech Europe Limited

Tel: + 44 (0) 1260 253846
Web: www.mactechurope.co.uk
Email: info@mactechurope.co.uk

UK Head Office: Unit 7 Scragg House | Langley | Macclesfield | Cheshire | SK11 0DG
Aberdeen Office: Mactech House | Howe Moss Drive | Dyce | Aberdeen | AB21 0GL

Rental Units
in the UK &
Internationally

Mactech Europe 810LC Clamshell Lathe

Mactech Europe

810LC Clamshell Lathe

Portable Machining Solutions



Mactech Europe offer portable pipe cutting machines for On-Site precision cutting and bevelling of most pipe sizes, schedules and materials.

The Clamshell Lathes cover a wide range of pipe sizes from 2" to 60" OD and are designed so that minimal radial and axial clearance are required for easy installation on in-line closed loop pipe.

Unlike other competitive cold cutters our lathes have more bearings making it the most versatile machine in the industry to cut and bevel pipe, re-machine flanges, machine shafts and more.

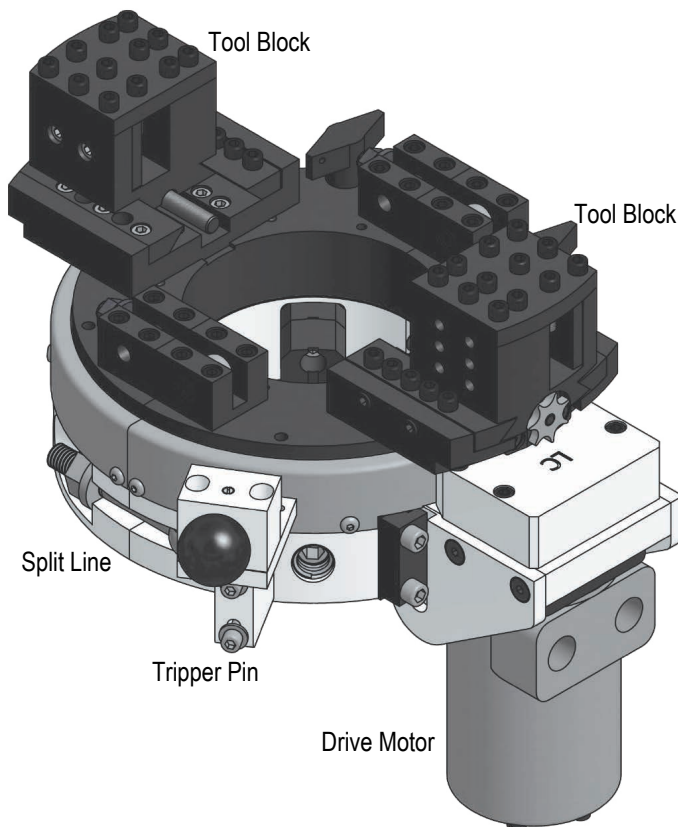

Mactech 810LC Clamshell



Features

- Sever or simultaneous Sever / Bevell 4" to 10" pipe.
- Cold Cutting in hazardous environments.
- Exceptionally rigid, split-frame for precise on-site machining.
- Tool Holder accepts standard 3/4" or 1" tool bits.
- Lightweight, low clearance design for easy handling in tight workspaces.
- Air Caddy (air filter & oiler) included with air drive systems
- Customer setups and drives available for your application.

Mactech Europe Limited

Tel: + 44 (0) 1260 253846
Web: www.mactech europe.co.uk
Email: info@mactech europe.co.uk

UK Head Office: Unit 7 Scragg House | Langley | Macclesfield | Cheshire | SK11 0DG
Aberdeen Office: Mactech House | Howe Moss Drive | Dyce | Aberdeen | AB21 0GL



Mactech
(EUROPE) LIMITED

Rental Units
in the UK &
Internationally



Mactech Europe 810LC Clamshell Lathe



Mactech
(EUROPE) LIMITED

Mactech Europe

810LC Clamshell Lathe



Application Range	4" to 10" Nominal pipe	
Feed	Feed Mechanism	7 Point Star Wheel & Tripper
	Feed Rate	.0035" (0.09 mm) per revolution
Drives	Air Drive Requirement 100cfm @ 100 psi (2.8m³/min @ 6.9 bar) Hydraulic Drive HPU Requirement 10-15 gpm @1000 psi (38-57lpm@69 bar) continuous pressure - includes hose whips and quick-disconnects	
Weights	Operating Weights include tool blocks, slides and drive motor 810LC Air Drive 88lbs (40kg) 810LC Hydraulic Drive 92lbs (42kg) Approximate Shipping Weights includes equipment and shipping crate 810LC Air Drive 177lbs (80kg) 810LC Hydraulic Drive 168lbs (76kg)	
Options	Full line of tool bits Right angle & reversible drives Single point machining attachment Axial Feed Machining attachment Counterbore / Facing attachment Hydraulic Power Unit	

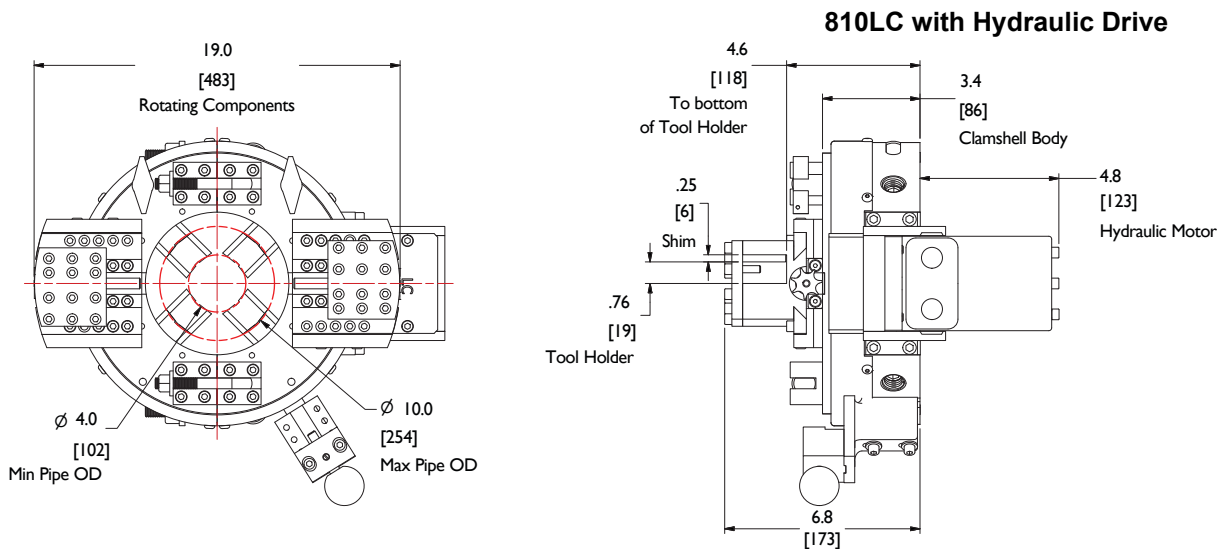
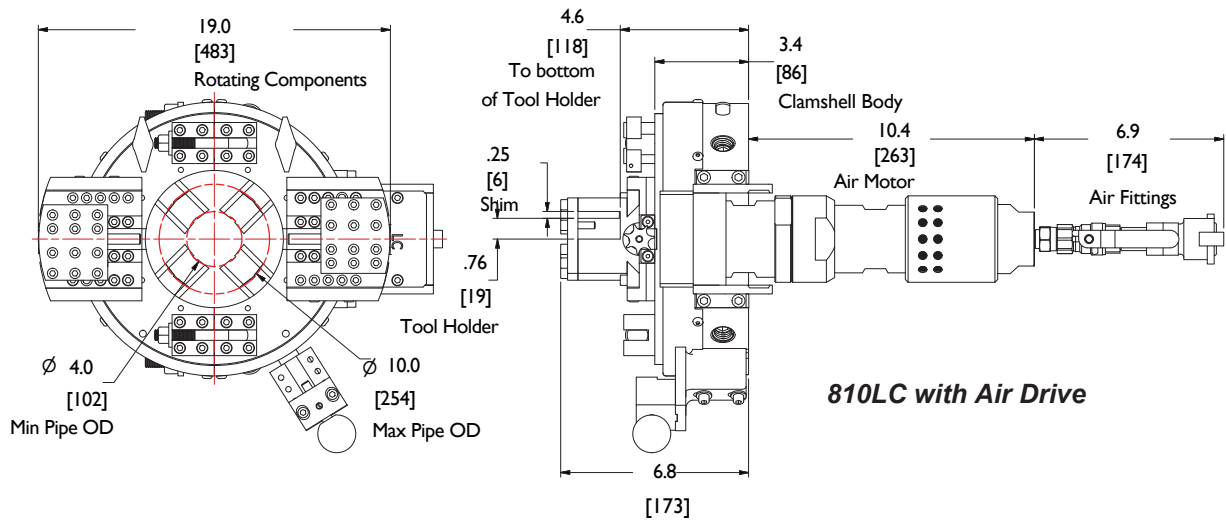

Mactech Europe Limited

Tel: + 44 (0) 1260 253846
Web: www.mactech europe.co.uk
Email: info@mactech europe.co.uk

UK Head Office: Unit 7 Scragg House | Langley | Macclesfield | Cheshire | SK11 0DG
Aberdeen Office: Mactech House | Howe Moss Drive | Dyce | Aberdeen | AB21 0GL

Rental Units
in the UK &
Internationally

Mactech Europe 812LC Clamshell Lathe

Mactech Europe

812LC Clamshell Lathe

Portable Machining Solutions



Mactech Europe offer portable pipe cutting machines for On-Site precision cutting and bevelling of most pipe sizes, schedules and materials.

The Clamshell Lathes cover a wide range of pipe sizes from 2" to 60" OD and are designed so that minimal radial and axial clearance are required for easy installation on in-line closed loop pipe.

Unlike other competitive cold cutters our lathes have more bearings making it the most versatile machine in the industry to cut and bevel pipe, re-machine flanges, machine shafts and more.

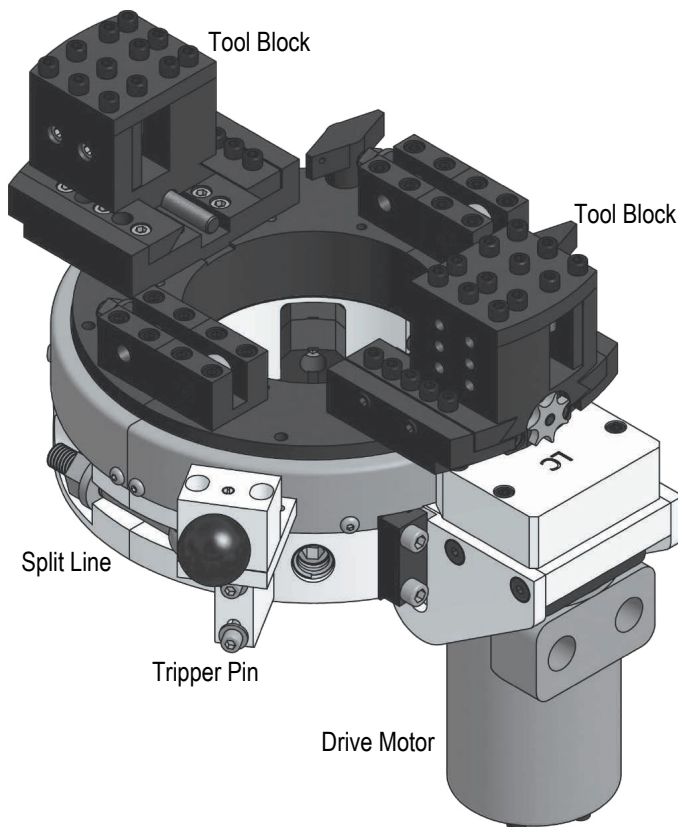

Mactech 812LC Clamshell



Features

- Sever or simultaneous Sever / Bevell 6" to 12" pipe.
- Cold Cutting in hazardous environments.
- Exceptionally rigid, split-frame for precise on-site machining.
- Tool Holder accepts standard 3/4" or 1" tool bits.
- Lightweight, low clearance design for easy handling in tight workspaces.
- Air Caddy (air filter & oiler) included with air drive systems
- Customer setups and drives available for your application.

Mactech Europe Limited

Tel: + 44 (0) 1260 253846
Web: www.mactechurope.co.uk
Email: info@mactechurope.co.uk

UK Head Office: Unit 7 Scragg House | Langley | Macclesfield | Cheshire | SK11 0DG
Aberdeen Office: Mactech House | Howe Moss Drive | Dyce | Aberdeen | AB21 0GL



Mactech
(EUROPE) LIMITED

Rental Units
in the UK &
Internationally



Mactech Europe 812LC Clamshell Lathe



Mactech
(EUROPE) LIMITED

Mactech Europe

812LC Clamshell Lathe



Application Range	6" to 12" nominal pipe	
Feed	Feed Mechanism	7 Point Star Wheel & Tripper
	Feed Rate	.0035" (0.09 mm) per revolution
Drives	Air Drive Requirement 100cfm @ 100 psi (2.8m³/min @ 6.9 bar) Hydraulic Drive HPU Requirement 10-15 gpm @1000 psi (38-57lpm@69 bar) continuous pressure - includes hose whips and quick-disconnects	
Weights	Operating Weights include tool blocks, slides and drive motor 812LC Air Drive 96lbs (44kg) 812LC Hydraulic Drive 100lbs (45kg) Approximate Shipping Weights includes equipment and shipping crate 812LC Air Drive 185lbs (84kg) 812LC Hydraulic Drive 176lbs (80kg)	
Options	Full line of tool bits Right angle & reversible drives Single point machining attachment Axial Feed Machining attachment Counterbore / Facing attachment Hydraulic Power Unit	

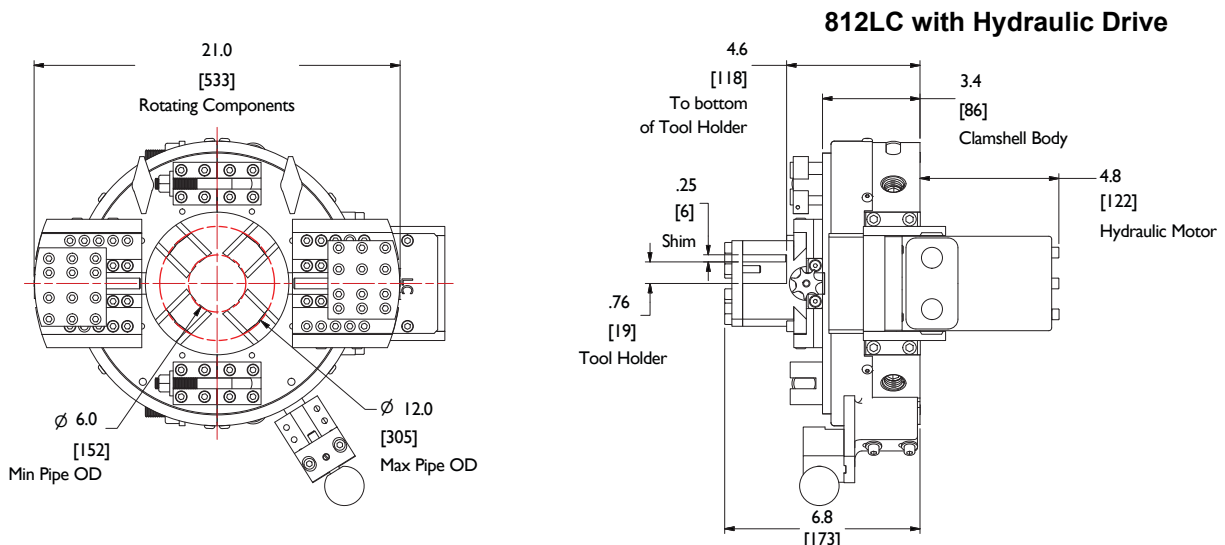
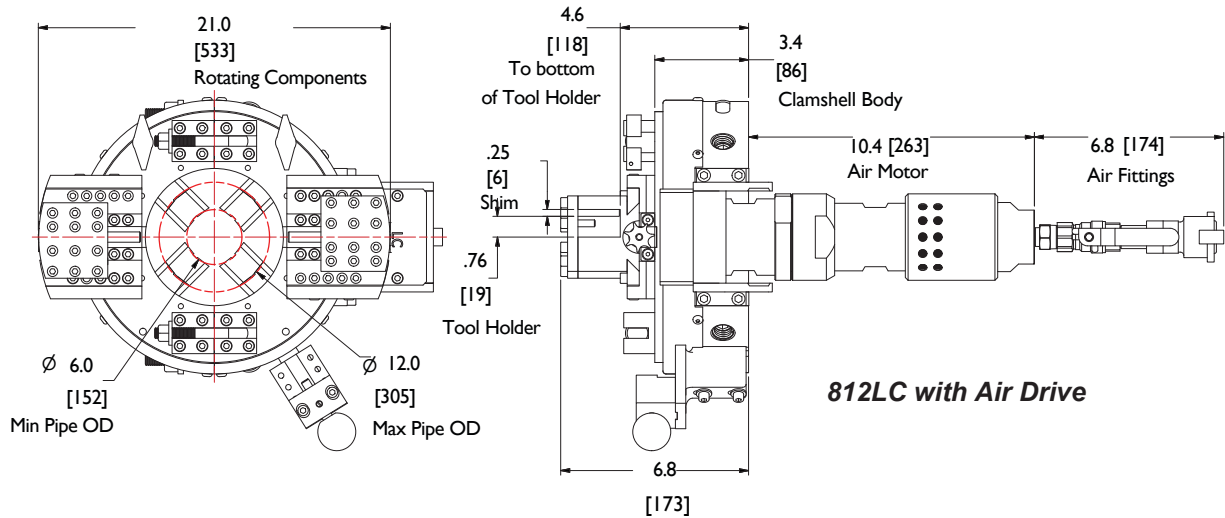

Mactech Europe Limited

Tel: + 44 (0) 1260 253846
Web: www.mactechurope.co.uk
Email: info@mactechurope.co.uk

UK Head Office: Unit 7 Scragg House | Langley | Macclesfield | Cheshire | SK11 0DG
Aberdeen Office: Mactech House | Howe Moss Drive | Dyce | Aberdeen | AB21 0GL

Mactech Europe

814LC Clamshell Lathe

Portable Machining Solutions



Mactech Europe offer portable pipe cutting machines for On-Site precision cutting and bevelling of most pipe sizes, schedules and materials.

The Clamshell Lathes cover a wide range of pipe sizes from 2" to 60" OD and are designed so that minimal radial and axial clearance are required for easy installation on in-line closed loop pipe.

Unlike other competitive cold cutters our lathes have more bearings making it the most versatile machine in the industry to cut and bevel pipe, re-machine flanges, machine shafts and more.

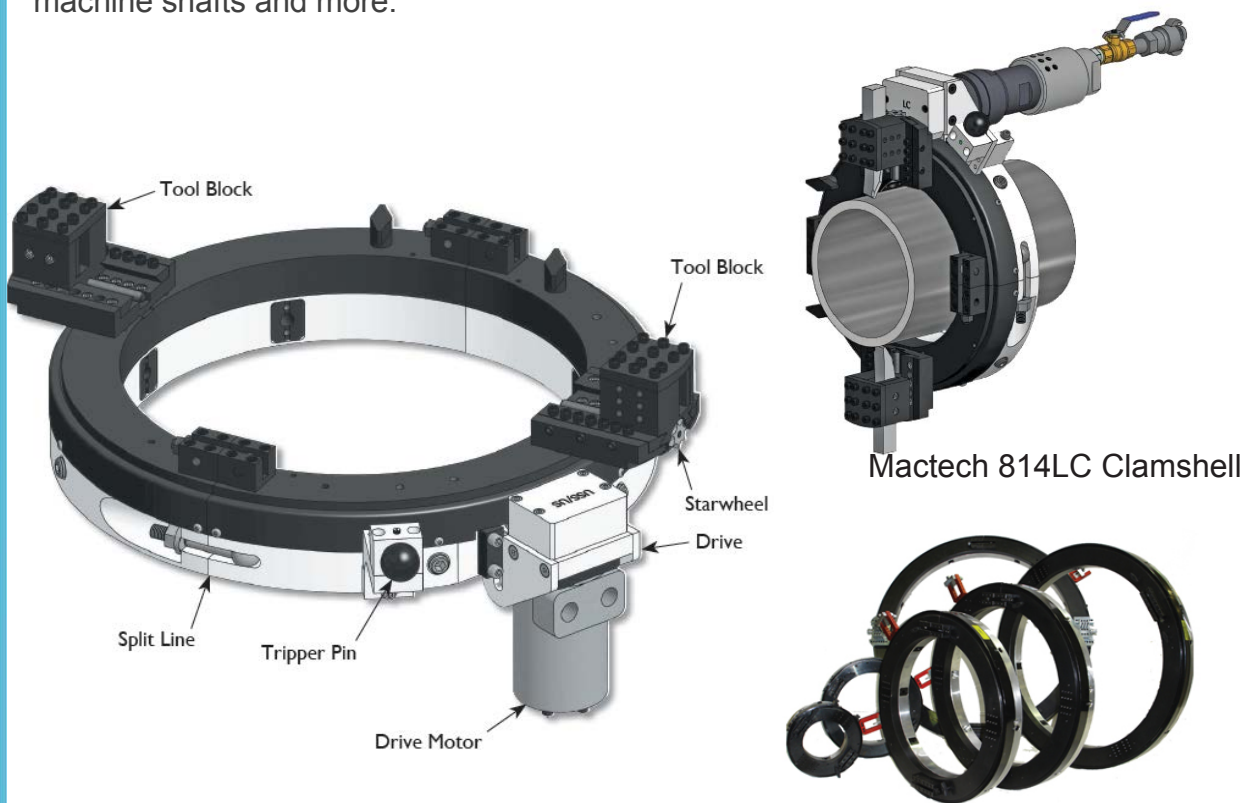

Features

- Sever or simultaneous Sever / Bevell 8" to 14" pipe.
- Cold Cutting in hazardous environments.
- Exceptionally rigid, split-frame for precise on-site machining.
- Tool Holder accepts standard 3/4" or 1" tool bits.
- Lightweight, low clearance design for easy handling in tight workspaces.
- Air Caddy (air filter & oiler) included with air drive systems
- Customer setups and drives available for your application.

Mactech Europe Limited

Tel: + 44 (0) 1260 253846
Web: www.mactech europe.co.uk
Email: info@mactech europe.co.uk

UK Head Office: Unit 7 Scragg House | Langley | Macclesfield | Cheshire | SK11 0DG
Aberdeen Office: Mactech House | Howe Moss Drive | Dyce | Aberdeen | AB21 0GL



Rental Units
in the UK &
Internationally

Mactech Europe



814LC Clamshell Lathe



Web Site

Mactech Europe 814LC Clamshell Lathe

Application Range	8" to 14" (203mm to 356mm) diameter pipe	
Feed	Feed Mechanism	7 Point Star Wheel & Tripper
	Feed Rate	.0035" (0.09 mm) per revolution
Drives	Air Drive Requirement 100cfm @ 100 psi (2.8m³/min @ 6.9 bar) Hydraulic Drive HPU Requirement 10-15 gpm @1000 psi (38-57lpm@69 bar) continuous pressure - includes hose whips and quick-disconnects	
Weights	Operating Weights include tool blocks, slides and drive motor 814LC Air Drive 100lbs (45kg) 814LC Hydraulic Drive 104lbs (47kg) Approximate Shipping Weights includes equipment and shipping crate 814LC Air Drive 189lbs (86kg) 814LC Hydraulic Drive 180lbs (82kg)	
Options	Full line of tool bits Right angle & reversible drives Single point machining attachment Axial Feed Machining attachment Counterbore / Facing attachment Hydraulic Power Unit	

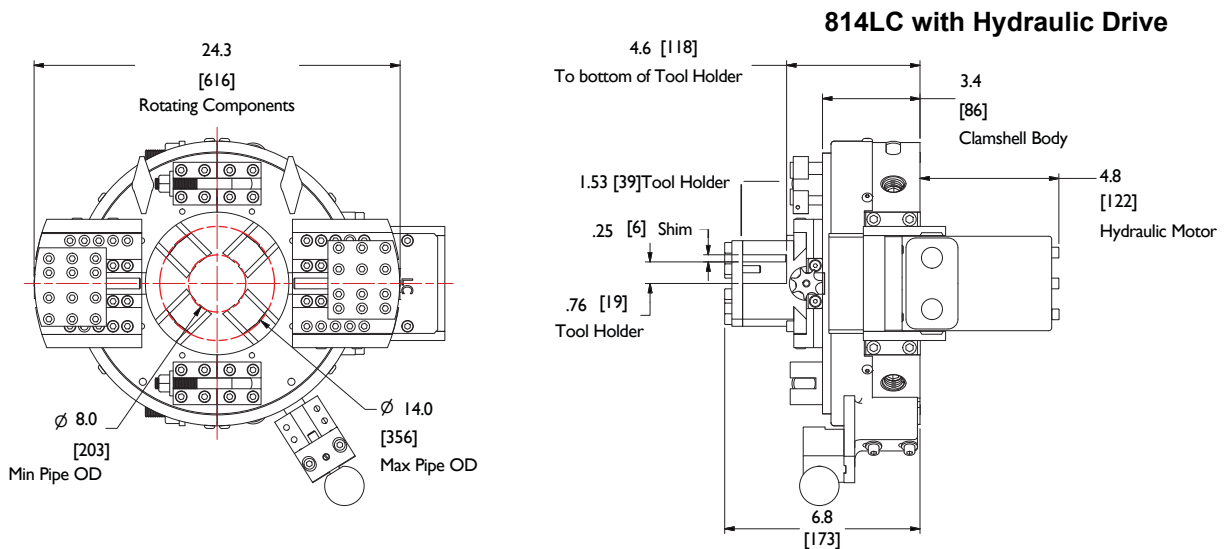
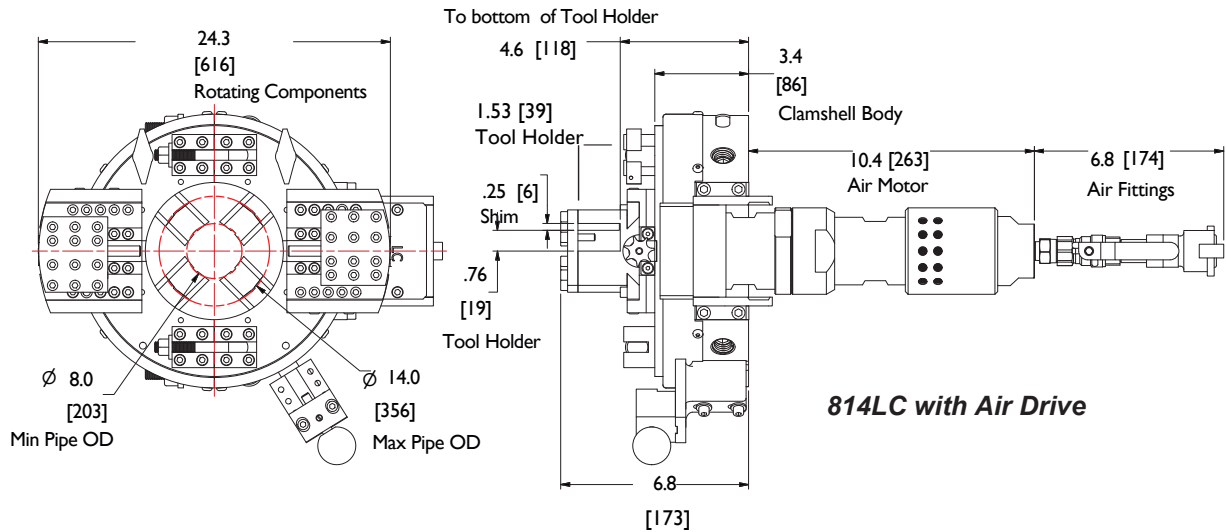

Mactech
(EUROPE) LIMITED

Mactech Europe Limited

Tel: + 44 (0) 1260 253846
Web: www.mactech europe.co.uk
Email: info@mactech europe.co.uk

UK Head Office: Unit 7 Scragg House | Langley | Macclesfield | Cheshire | SK11 0DG
Aberdeen Office: Mactech House | Howe Moss Drive | Dyce | Aberdeen | AB21 0GL

Rental Units
in the UK &
Internationally

Mactech Europe 816LC Clamshell Lathe

Mactech Europe

816LC Clamshell Lathe

Portable Machining Solutions



Mactech Europe offer portable pipe cutting machines for On-Site precision cutting and bevelling of most pipe sizes, schedules and materials.

The Clamshell Lathes cover a wide range of pipe sizes from 2" to 60" OD and are designed so that minimal radial and axial clearance are required for easy installation on in-line closed loop pipe.

Unlike other competitive cold cutters our lathes have more bearings making it the most versatile machine in the industry to cut and bevel pipe, re-machine flanges, machine shafts and more.

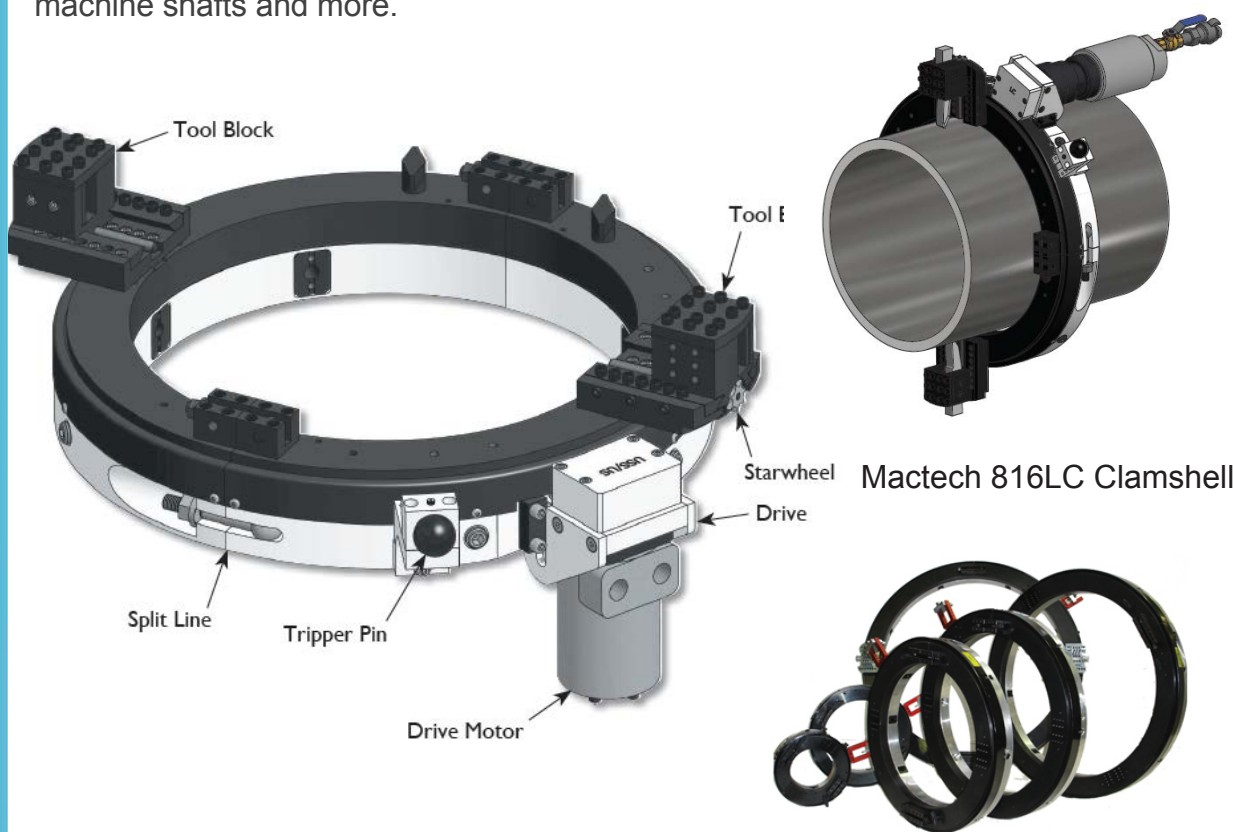

Mactech 816LC Clamshell

Features

- Sever or simultaneous Sever / Bevell 10" to 16" pipe.
- Cold Cutting in hazardous environments.
- Exceptionally rigid, split-frame for precise on-site machining.
- Tool Holder accepts standard 3/4" or 1" tool bits.
- Lightweight, low clearance design for easy handling in tight workspaces.
- Air Caddy (air filter & oiler) included with air drive systems
- Customer setups and drives available for your application.

Mactech Europe Limited

Tel: + 44 (0) 1260 253846
Web: www.mactech europe.co.uk
Email: info@mactech europe.co.uk

UK Head Office: Unit 7 Scragg House | Langley | Macclesfield | Cheshire | SK11 0DG
Aberdeen Office: Mactech House | Howe Moss Drive | Dyce | Aberdeen | AB21 0GL



Mactech
(EUROPE) LIMITED

Rental Units
in the UK &
Internationally



Mactech Europe 816LC Clamshell Lathe

Mactech Europe

816LC Clamshell Lathe



Application Range	10" to 16" (254 to 406mm) diameter pipe	
Feed	Feed Mechanism	7 Point Star Wheel & Tripper
	Feed Rate	.0035" (0.09 mm) per revolution
Drives	Air Drive Requirement 100cfm @ 100 psi (2.8m³/min @ 6.9 bar) Hydraulic Drive HPU Requirement 10-15 gpm @1000 psi (38-57lpm@69 bar) continuous pressure - includes hose whips and quick-disconnects	
Weights	Operating Weights include tool blocks, slides and drive motor 816LC Air Drive 107lbs (49kg) 816LC Hydraulic Drive 105lbs (48kg) Approximate Shipping Weights includes equipment and shipping crate 816LC Air Drive 231lbs (105kg) 816LC Hydraulic Drive 216lbs (98kg)	
Options	Full line of tool bits Right angle & reversible drives Single point machining attachment Axial Feed Machining attachment Counterbore / Facing attachment Hydraulic Power Unit	

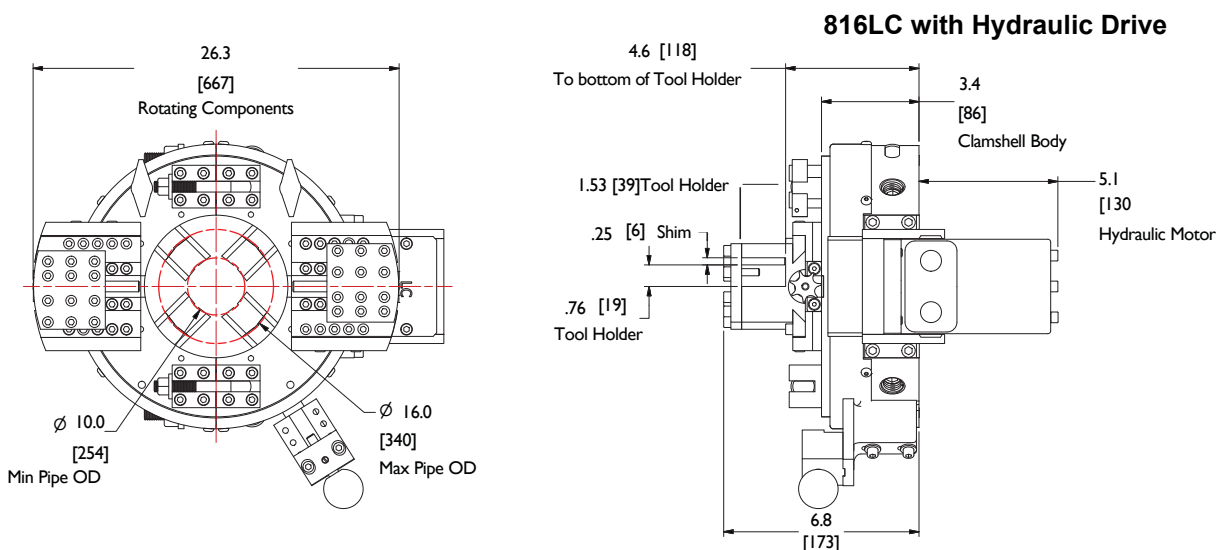
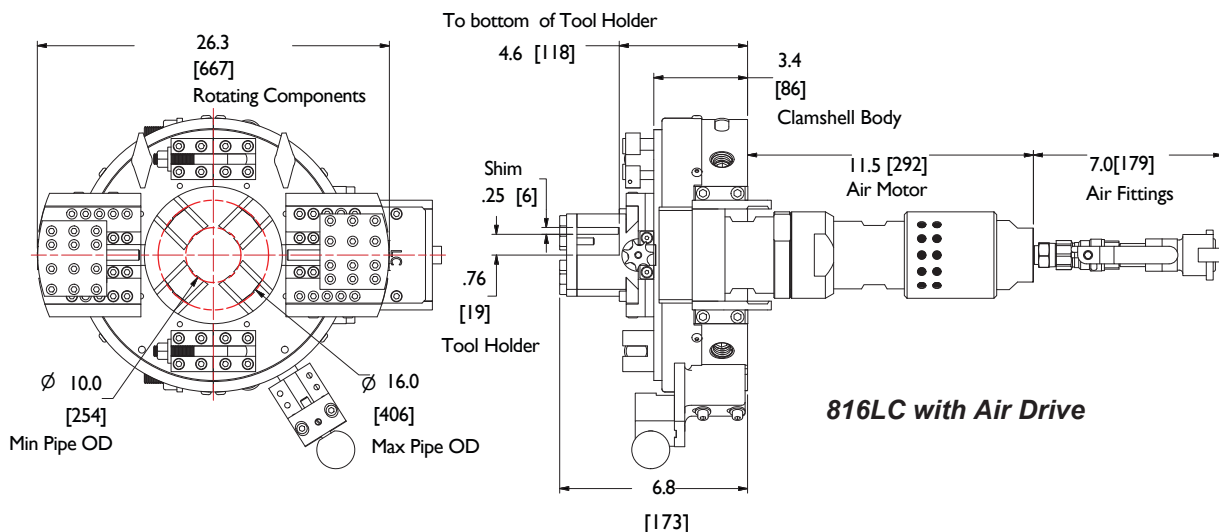

Mactech
(EUROPE) LIMITED

Mactech Europe Limited

Tel: + 44 (0) 1260 253846
Web: www.mactech europe.co.uk
Email: info@mactech europe.co.uk

UK Head Office: Unit 7 Scragg House | Langley | Macclesfield | Cheshire | SK11 0DG
Aberdeen Office: Mactech House | Howe Moss Drive | Dyce | Aberdeen | AB21 0GL